



GENERAL DESCRIPTION

The RZC3008S is the high cell density trench N-Channel MOSFET, which provide excellent $R_{DS(ON)}$ and gate charge for most of the synchronous buck converter applications.

The RZC3008S meet the ROHS and Green Product requirement with full function reliability approved.

PIN CONFIGURATION

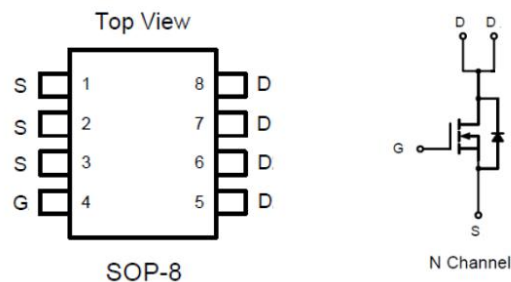

FEATURES

- 30V/10A, $R_{DS(ON)} = 8m\Omega$ $V_{GS} = 10V$ (TPY.)
- 30V/10A, $R_{DS(ON)} = 11m\Omega$ $V_{GS} = 4.5V$ (TPY.)
- 100% EAS Guaranteed
- Green Device Available
- Supper Low Gate Charge
- Excellent Cdv/dt effect decline
- Advanced high cell density Trench technology
- SOP-8 package design

APPLICTIONS

- Power Management in Notebook Computer
- Portable Equipment
- Battery Powered Systems

ORDERING INFORMATION

Part Number	Package	Top Marking	Packing
RZC3008S	SOP-8	S3008	3000PCS/Real

**MAXIMUM RATINGS** ($T_a = 25^\circ\text{C}$)

Parameter	Symbol	Value	Units
Drain to Source Voltage	V_{DSS}	30	V
Gate to Source Voltage	V_{GSS}	± 20	V
Continuous Drain Current	I_D	25°C	10 A
		85°C	8 A
Pulsed Drain Current	$I_{D(pulse)}$	40	A
Maximum Power Dissipation	$P_D(25^\circ\text{C})$	1.5	W
Single Pulse Avalanche Energy	EAS	61	mJ
Operating Junction Temperature	T_J	+150	$^\circ\text{C}$
Storage Temperature	T_{STG}	-55-+150	$^\circ\text{C}$
Lead Temperature for Soldering Purposes(1/8" from case for 10 s)	T_L	260	$^\circ\text{C}$



ELECTRICAL CHARACTERISTICS (TA = 25°C)

Parameter	Symbol	Test Conditions	MIN.	TYP.	MAX	Units
Drain-Source Breakdown Voltage	BV _{DSS}	V _{GS} =0V, I _{DS} =250uA	30			V
Zero Gate Voltage Drain Current	I _{DSS}	V _{DS} =24V, V _{GS} =0V T _J =25°C			1	uA
		V _{DS} =24V, V _{GS} =0V T _J =55°C			5	uA
Gate Leakage Current	I _{GSS}	V _{GS} =±20V, V _{DS} =0V			±100	nA
Gate threshold voltage	V _{GS(TH)}	V _{DS} =V _{GS} , I _D =250μA	1.2	1.5	2.5	V
Drain to Source On-state Resistance _(note 2)	R _{DS(ON)}	V _{GS} =10V, I _D =10A		8	9	mΩ
		V _{GS} = 4.5V, I _D =8A		11	14	mΩ
Drain-Source Diode Forward Voltage	V _{SD}	I _S =1A, V _{GS} =0V			1.2	V
Gate Resistance	R _g	V _{DS} =0V, V _{GS} =0V, f=1MHz		2.2	3.8	Ω
Input Capacitance	C _{iss}	V _{DS} =15V, V _{GS} =0V, f=1MHz		1317	1845	pF
Output Capacitance	C _{oss}			163	229	pF
Reverse Transfer Capacitance	C _{rss}			131	184	pF
Total Gate Charge (10V)	Q _G	V _{DD} =15V, V _{GS} =4.5V, I _D =10A		13	18	nC
Gate-Source Charge	Q _{GS}			4.5	6	nC
Gate-Drain Charge	Q _{GD}			5	7.5	nC
Turn-On Delay Time	T _{d(on)}	V _{DD} =15V, V _{GS} =10V, R _G =3.3Ω, I _D =10A		6	13	nS
Rise Time	T _r			59	106	
Turn-Off Delay Time	T _{d(off)}			28	55	
Fall Time	T _f			8	17	

DIODE CHARACERISTICS

Parameter	Symbol	Test Conditions	MIN	TYP	MAX	Units
Drain-Source Diode Forward Voltage	V _{SD}	I _S =1A, V _{GS} =0V			1.2	V
Continuous Source Current ^{1,5}	I _S	V _G =V _D =0V, Force Current			10	A
Reverse Recovery Time	t _{rr}	I _F =10A, T _J =25°C, di/dt=100A/us,		12.5		nS
Reverse Recovery Charge	Q _{rr}				5	nC



TYPICAL CHARACTERISTICS

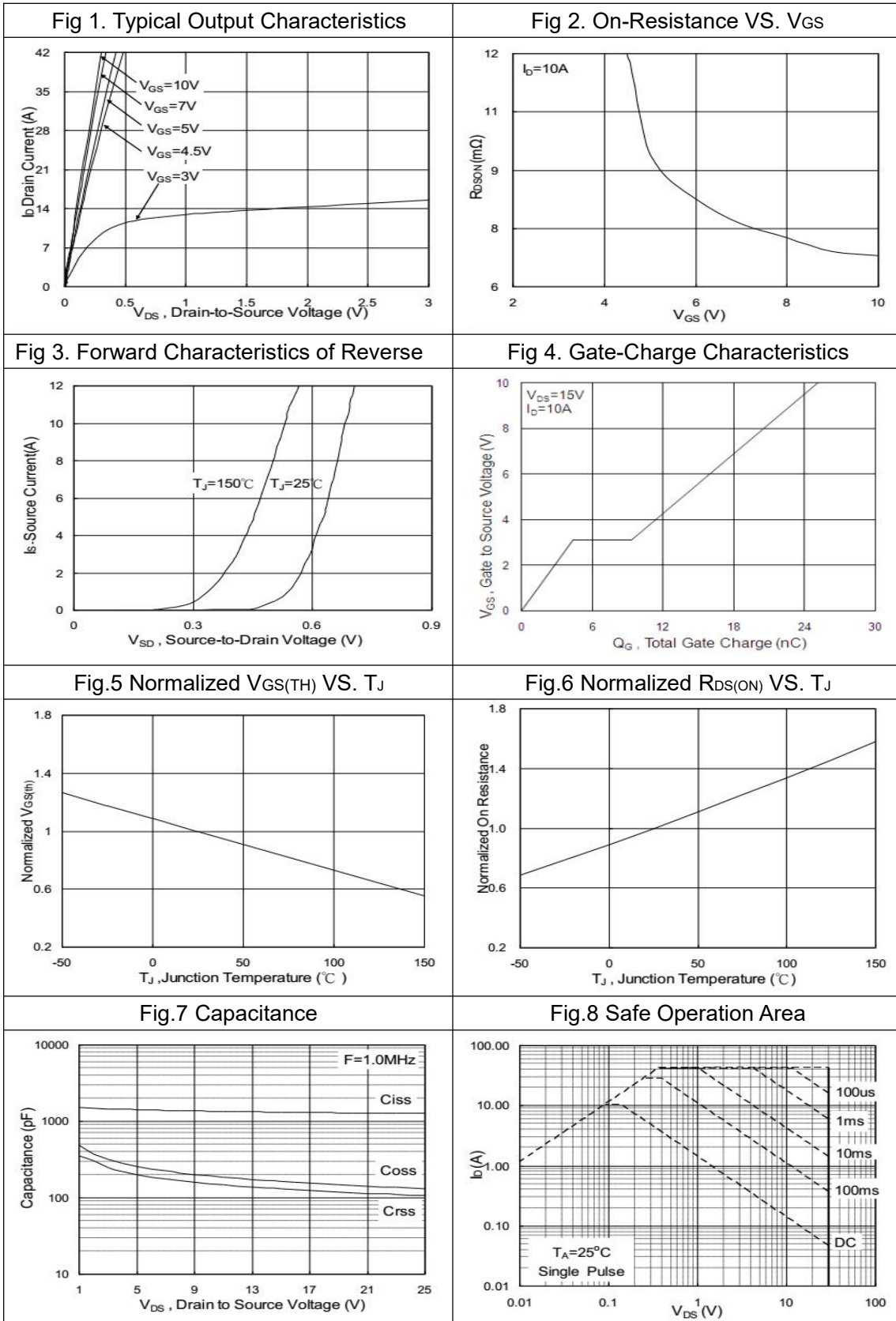
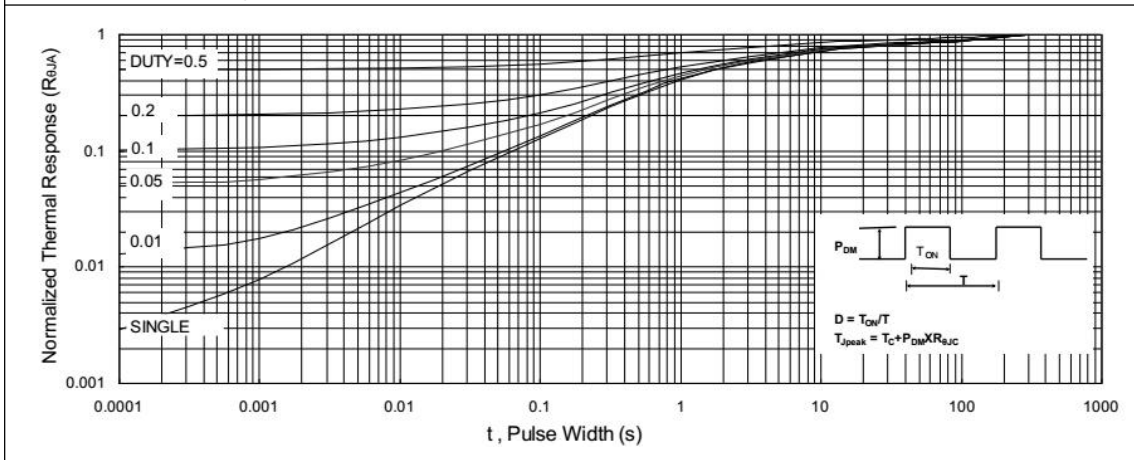
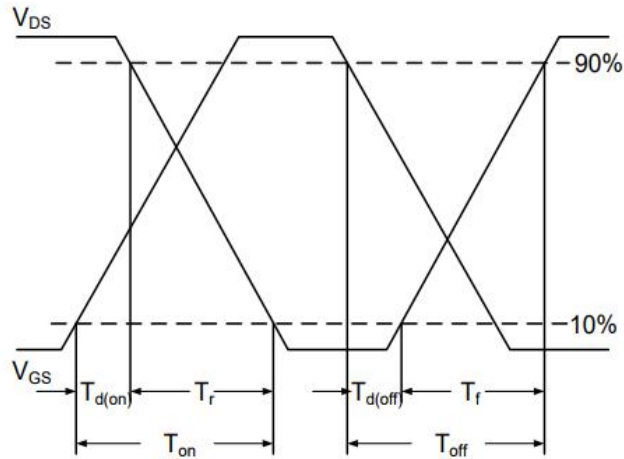



Fig.9 Normalized Maximum Transient Thermal Impedance



Switching Time Waveform



Unclamped Inductive Switching Waveform

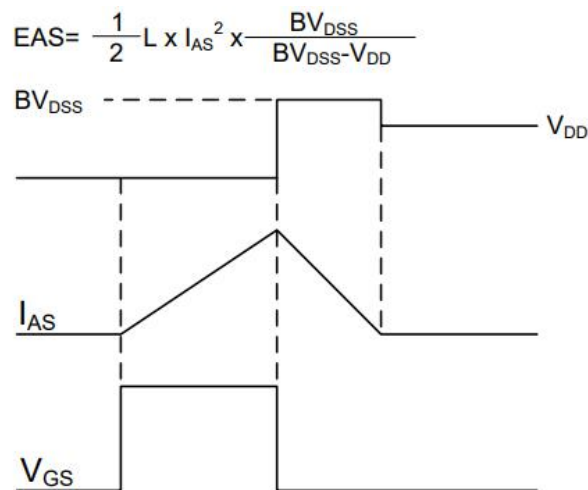



PACKAGE DIMENSIONS

SOP-8

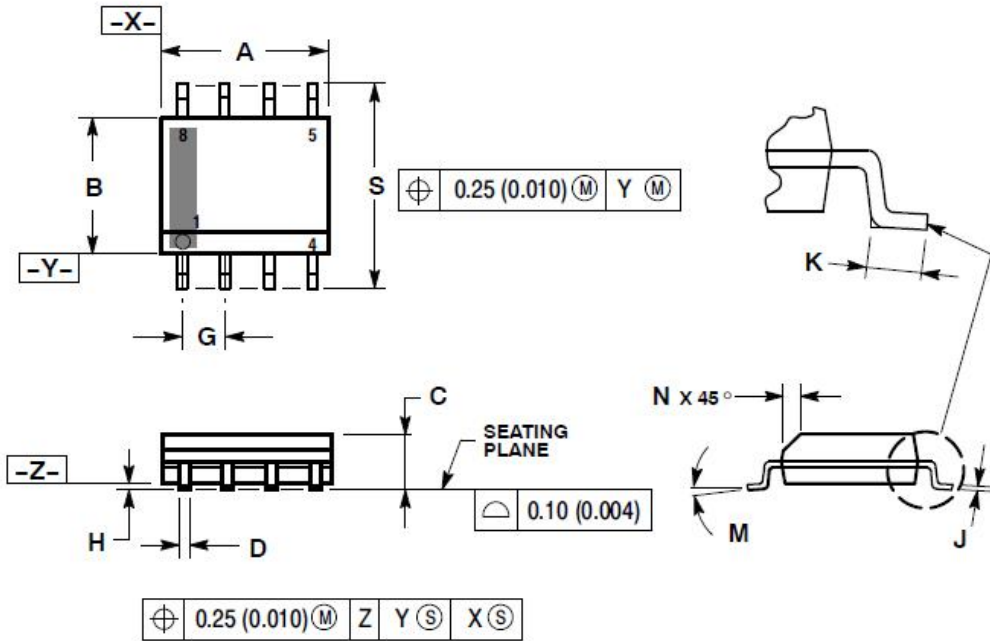

SOLDERING FOOTPRINT*

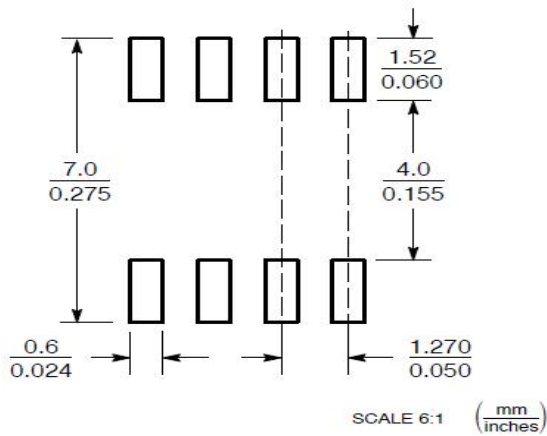

DIM	MILLIMETERS		INCHES	
	MIN	MAX	MIN	MAX
A	4.80	5.00	0.189	0.197
B	3.80	4.00	0.150	0.157
C	1.35	1.75	0.053	0.069
D	0.33	0.51	0.013	0.020
G	1.27 BSC		0.050 BSC	
H	0.10	0.25	0.004	0.010
J	0.19	0.25	0.007	0.010
K	0.40	1.27	0.016	0.050
M	0°	8°	0°	8°
N	0.25	0.50	0.010	0.020
S	5.80	6.20	0.228	0.244